

Contact Details

Before using the product, please check the guide pages at the front of this catalog.

Internet

<http://www.daikinpmc.com/en/>

For latest information, PDF catalogs and operation manuals

Type C2 Solenoid Operated Proportional Low-pressure Reducing Valve



JIS graphic symbols for hydraulic system

Simplified symbols

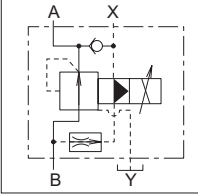

Detailed symbols

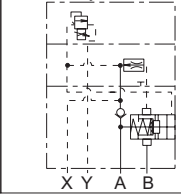

Features

- These normally closed type valves are capable of pressure control from the low pressure range because of a structure that supplies the pilot flow rate from the primary side of the valve to the built-in flow rate adjusting valve.

Nomenclature

※ - **C2GLP** - **G 03** - ※ ※ - **10** - ※ ※
1 2 3 4 5 6 7 8

1 Applicable fluid code

No designation: Petroleum-based hydraulic fluid,
water-glycol hydraulic fluid
F: Phosphate ester hydraulic fluid

2 Model No.

C2GLP: Type C2 solenoid operated proportional
low-pressure reducing valve

3 Connections

G: Gasket mount type

4 Nominal diameter

03: $\frac{3}{8}$

5 Pressure adjustment range

03: Up to 3.5 MPa {Up to 35 kgf/cm²}
1: Up to 7 MPa {Up to 70 kgf/cm²}
2: UP to 16 MPa {UP to 160 kgf/cm²}

6 Design No.

(The design No. is subject to change)

7 Option code

No designation: DIN connector mounting position: Top
L: DIN connector mounting position, left side
R: DIN connector mounting position, right side

8 Solenoid codes

No designation: DC 24 V solenoid
N: DC 12 V solenoid

8: Solenoid code and applicable driver model code

Solenoid codes	Solenoid	Rated current (20°C) mA	Coil resistance (20°C) Ω	Applicable driver	
				Model code	Power supply voltage
No designation	DC 24 V solenoid	850	26	KC-6-10	AC 100, 200, 220 V (Common for 50 and 60 Hz)
N	DC 12 V solenoid	1700	6.5	ZH-6-10	DC 24 V

Specifications

Model code	Nominal diameter	Maximum operating pressure MPa {kgf/cm ² }	Pressure adjustment range *1 MPa {kgf/cm ² }	Maximum flow rate L/min	Drainage rate L/min	Hysteresis	Repeatability	Mass kg
C2GLP-G03-03-10	$\frac{3}{8}$	25 {250}	Up to 3.5 {Up to 35}	80	0.5 to 0.6	No greater than 3% of the maximum adjusting pressure	No greater than 1% of the maximum adjusting pressure	6.4
C2GLP-G03- 1-10			Up to 7 {Up to 70}					
C2GLP-G03- 2-10			Up to 16 {Up to 160}					

Note: *1 The minimum adjustment pressure varies depending on the flow rate. See the flow rate - pressure characteristics.

Contact Details

Before using the product, please check the guide pages at the front of this catalog.

Internet

<http://www.daikinpmc.com/en/>

For latest information, PDF catalogs and operation manuals

Sub-plate model code

- The sub-plate is not provided with the valve. Order it separately as required by specifying the model code given in the table below.

Model code	Nominal diameter	Connection port diameter	Mass kg
JGB-03M	3/8	Rc3/8	1.6
JGB-03M04		Rc1/2	

Refer to Page S-6 for the dimensions of the sub-plate.

Accessories

Hexagon socket head cap bolt	Number	Tightening torque N·m {kgf·cm}
M10 × 60	4	51 to 68 {510 to 680}

Handling

- Directly connect the drain piping to the tank without merging it with other tank piping.
- To achieve stable pressure control, completely remove air by loosening the air bleeding screw and fill the inside of the valve with fluid.
- To ensure good pressure reducing performance, set the primary side main circuit pressure and the secondary pressure reducing circuit pressure such that there is a minimum difference of 1 MPa {10 kgf/cm²}.
- The minimum pressure adjusting screw (manual adjusting screw) is factory adjusted before shipment but it can be used to adjust the pressure when electric current cannot be applied to the solenoid during initial adjustment or due to electrical failure. Before adjusting the pressure with the pressure adjusting screw, check and note the initial position of the screw. The pressure is increased by turning the screw clockwise. After recovering the normal operation status, return the screw to the initial position and tighten the lock nut.

Performance curves (viscosity: 32 mm²/s {cSt})

Input current - pressure characteristics

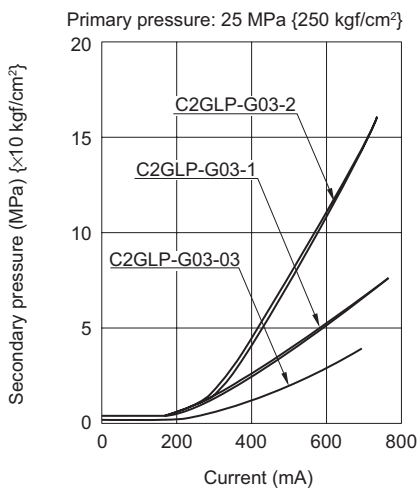

Flow rate - pressure characteristics

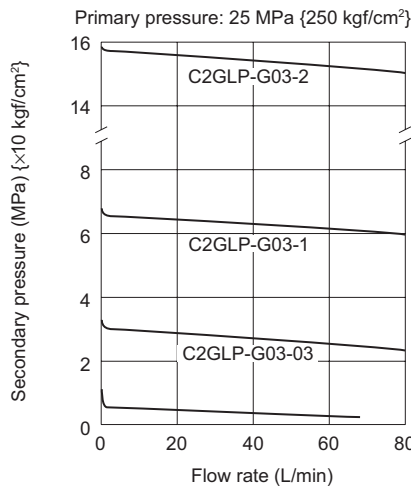

Pressure drop characteristics

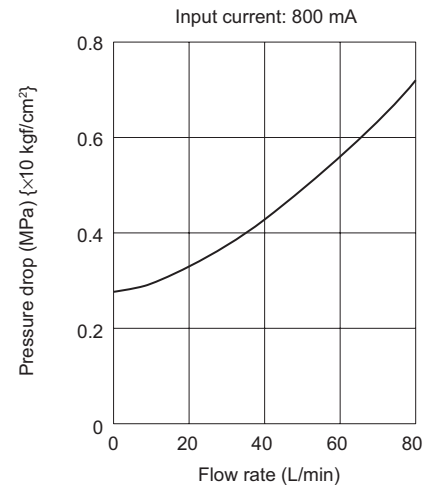

Flow rate - pressure characteristics

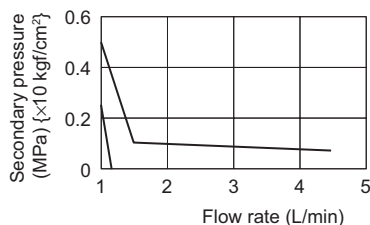

Note: The minimum adjustment pressure at 0 L/min is 0.28 MPa {2.8 kgf/cm²}.

Contact Details

Before using the product, please check the guide pages at the front of this catalog.

Internet

<http://www.daikinpmc.com/en/>

For latest information, PDF catalogs and operation manuals

External dimension diagram

C2GLP-G03

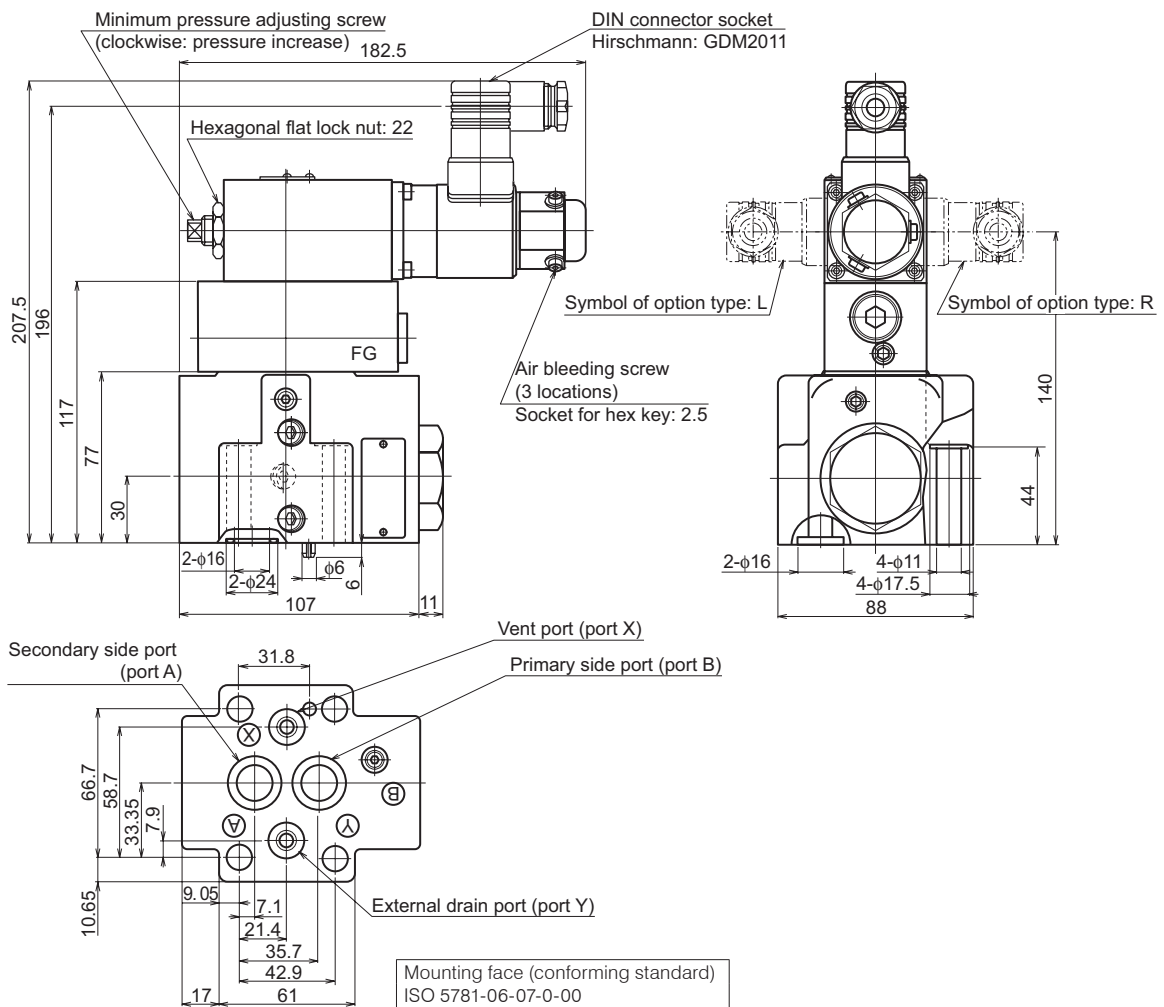

Sectional structural diagram

C2GLP-G03

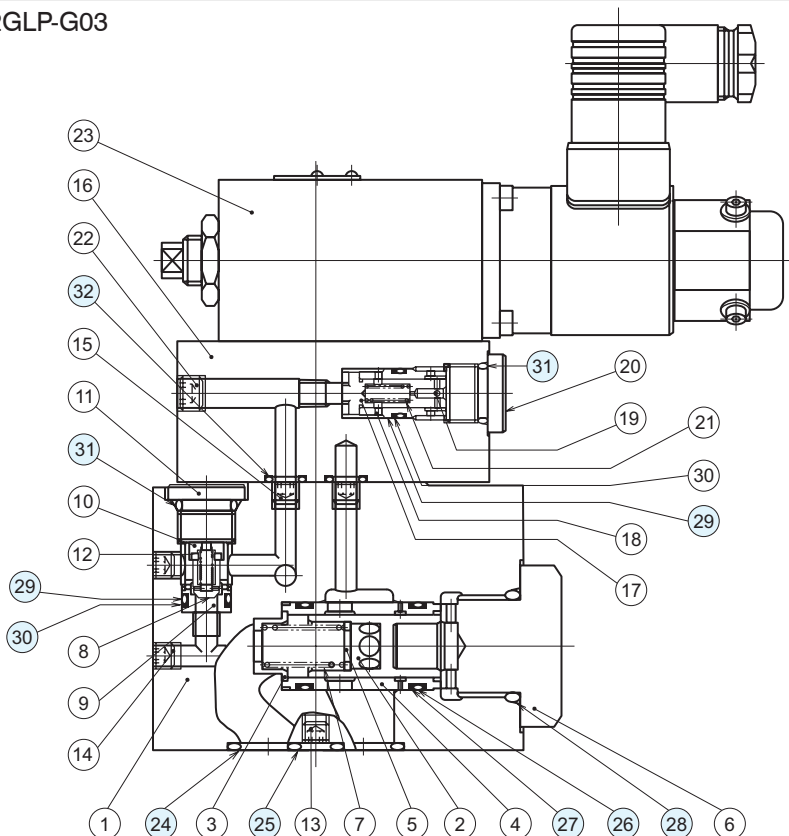

Sealing part table

Part No.	Name	Quantity	Part specifications
24	O-ring	2	JIS B 2401 1B P20
25	O-ring	2	JIS B 2401 1B P12
26	O-ring	2	AS568-020 (NBR, Hs90)
27	Backup ring	4	Spiral for AS568-020
28	O-ring	1	AS568-215 (NBR, Hs90)
29	O-ring	2	AS568-013 (NBR, Hs90)
30	Backup ring	2	Bias cut for AS568-013
31	O-ring	2	JIS B 2401 1B P14
32	O-ring	4	JIS B 2401 1B P9